

6

LINES AND ANGLES

EXERCISE 6.1

Q.1. In the figure lines AB and CD intersect at O . If $\angle AOC + \angle BOE = 70^\circ$ and $\angle BOD = 40^\circ$, find $\angle BOE$ and reflex $\angle COE$.

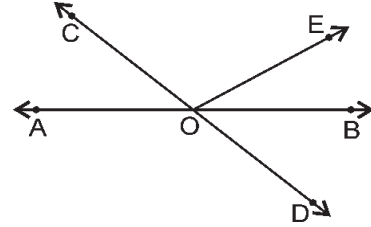

Sol. Lines AB and CD intersect at O .

$$\angle AOC + \angle BOE = 70^\circ \quad (\text{Given}) \quad \dots(1)$$

$$\angle BOD = 40^\circ \quad (\text{Given}) \quad \dots(2)$$

Since, $\angle AOC = \angle BOD$
(Vertically opposite angles)

Therefore, $\angle AOC = 40^\circ$ [From (2)]

and $40^\circ + \angle BOE = 70^\circ$ [From (1)]

$$\Rightarrow \angle BOE = 70^\circ - 40^\circ = 30^\circ$$

Also, $\angle AOC + \angle BOE + \angle COE = 180^\circ$ (\because AOB is a straight line)

$$\Rightarrow 70^\circ + \angle COE = 180^\circ \quad [\text{Form (1)}]$$

$$\Rightarrow \angle COE = 180^\circ - 70^\circ = 110^\circ$$

Now, reflex $\angle COE = 360^\circ - 110^\circ = 250^\circ$

Hence, $\angle BOE = 30^\circ$ and reflex $\angle COE = 250^\circ$ **Ans.**

Q.2. In the figure, lines XY and MN intersect at O . If $\angle POY = 90^\circ$ and $a : b = 2 : 3$, find c .

Sol. In the figure, lines XY and MN intersect at O and $\angle POY = 90^\circ$.

Also, given $a : b = 2 : 3$

Let $a = 2x$ and $b = 3x$.

Since, $\angle XOM + \angle POM + \angle POY = 180^\circ$
(Linear pair axiom)

$$\Rightarrow 3x + 2x + 90^\circ = 180^\circ$$

$$\Rightarrow 5x = 180^\circ - 90^\circ$$

$$\Rightarrow x = \frac{90^\circ}{5} = 18^\circ$$

$\therefore \angle XOM = b = 3x = 3 \times 18^\circ = 54^\circ$

and $\angle POM = a = 2x = 2 \times 18^\circ = 36^\circ$

Now, $\angle XON = c = \angle MOY = \angle POM + \angle POY$
(Vertically opposite angles)
 $= 36^\circ + 90^\circ = 126^\circ$

Hence, $c = 126^\circ$ **Ans.**

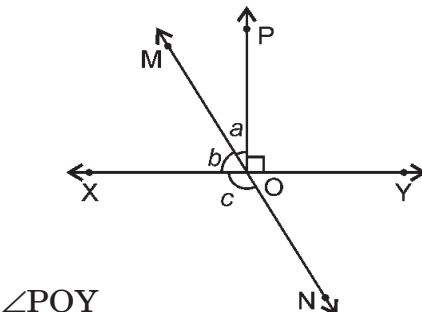
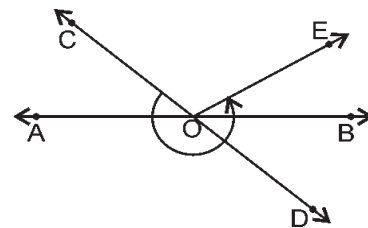

Q.3. In the figure, $\angle PQR = \angle PRQ$, then prove that $\angle PQS = \angle PRT$.

Sol. $\angle PQS + \angle PQR = 180^\circ$... (1)
 (Linear pair axiom)
 $\angle PRQ + \angle PRT = 180^\circ$... (2)
 (Linear pair axiom)
 But, $\angle PQR = \angle PRQ$ (Given)
 \therefore From (1) and (2)
 $\angle PQS = \angle PRT$ **Proved.**

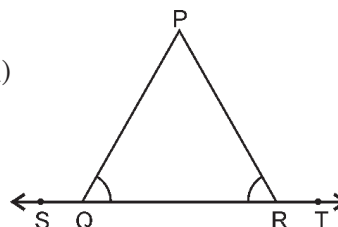
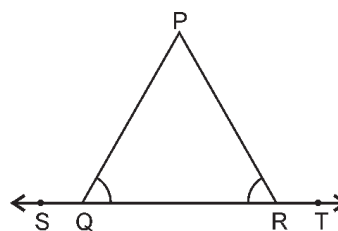

Q.4. In the figure, if $x + y = w + z$, then prove that AOB is a line.

Sol. Assume AOB is a line.
 Therefore, $x + y = 180^\circ$... (1)
 [Linear pair axiom]
 $w + z = 180^\circ$... (2)
 [Linear pair axiom]
 Now, from (1) and (2)
 $x + y = w + z$

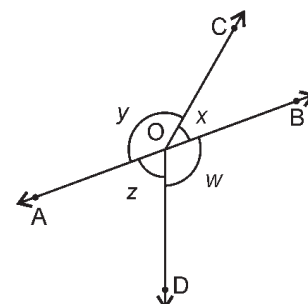
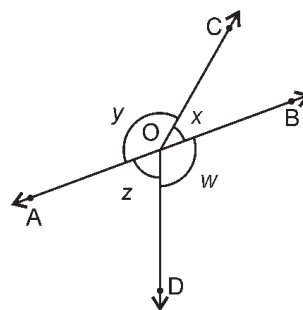

Hence, our assumption is correct, AOB is a line **Proved.**

Q.5. In the figure, POQ is a line. Ray OR is perpendicular to line PQ. OS is another ray lying between rays OP and OR. Prove that

$$\angle ROS = \frac{1}{2} (\angle QOS - \angle POS)$$

Sol. $\angle ROS = \angle ROP - \angle POS$... (1)
 and $\angle ROS = \angle QOS - \angle QOR$... (2)

Adding (1) and (2),

$$\angle ROS + \angle ROS = \angle QOS - \angle QOR + \angle ROP - \angle POS$$

$$\Rightarrow 2\angle ROS = \angle QOS - \angle POS (\because \angle QOR = \angle ROP = 90^\circ)$$

$$\Rightarrow \angle ROS = \frac{1}{2} (\angle QOS - \angle POS) \text{ **Proved.**}$$

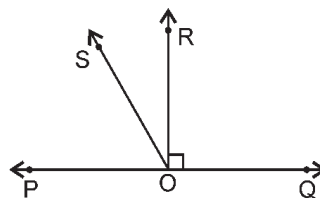
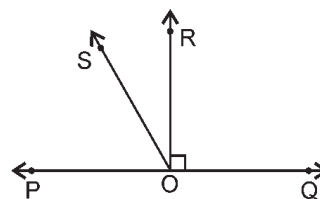

Q.6. It is given that $\angle XYZ = 64^\circ$ and XY is produced to point P . Draw a figure from the given information. If ray YQ bisects $\angle ZYP$, find $\angle XYQ$ and reflex $\angle QYP$.

Sol. From figure,

$$\angle XYZ = 64^\circ \quad (\text{Given})$$

$$\text{Now, } \angle ZYP + \angle XYZ = 180^\circ$$

(Linear pair axiom)

$$\Rightarrow \angle ZYP + 64^\circ = 180^\circ$$

$$\Rightarrow \angle ZYP = 180^\circ - 64^\circ = 116^\circ$$

Also, given that ray YQ bisects $\angle ZYP$.

$$\text{But, } \angle ZYP = \angle QYP = \angle QYZ = 116^\circ$$

$$\text{Therefore, } \angle QYP = 58^\circ \text{ and } \angle QYZ = 58^\circ$$

$$\text{Also, } \angle XYQ = \angle XYZ + \angle QYZ$$

$$\Rightarrow \angle XYQ = 64^\circ + 58^\circ = 122^\circ$$

$$\text{and reflex } \angle QYP = 360^\circ - \angle QYP = 360^\circ - 58^\circ = 302^\circ \quad (\because \angle QYP = 58^\circ)$$

$$\text{Hence, } \angle XYQ = 122^\circ \text{ and reflex } \angle QYP = 302^\circ \text{ Ans.}$$

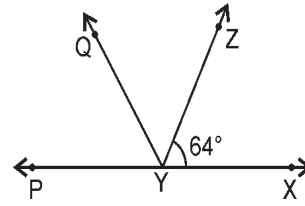

6

LINES AND ANGLES

EXERCISE 6.2

Q.1. In the figure, find the values of x and y and then show that $AB \parallel CD$.

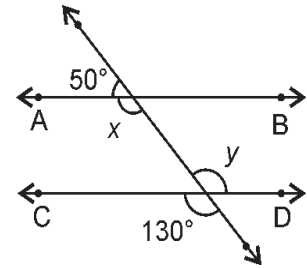

Sol. In the given figure, a transversal intersects two lines AB and CD such that

$$x + 50^\circ = 180^\circ \quad (\text{Linear pair axiom})$$

$$\Rightarrow x = 180^\circ - 50^\circ$$

$$= 130^\circ$$

$$y = 130^\circ \quad (\text{Vertically opposite angles})$$

Therefore, $\angle x = \angle y = 130^\circ$ (Alternate angles)

$\therefore AB \parallel CD$ (Converse of alternate angles axiom) **Proved.**

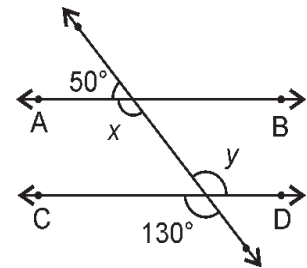

Q.2. In the figure, if $AB \parallel CD$, $CD \parallel EF$ and $y : z = 3 : 7$, find x .

Sol. In the given figure, $AB \parallel CD$, $CD \parallel EF$ and $y : z = 3 : 7$.

$$\text{Let } y = 3a \text{ and } z = 7a$$

$$\angle DHI = y \quad (\text{vertically opposite angles})$$

$$\angle DHI + \angle FIH = 180^\circ$$

(Interior angles on the same side of the transversal)

$$\Rightarrow y + z = 180^\circ$$

$$\Rightarrow 3a + 7a = 180^\circ$$

$$\Rightarrow 10a = 180^\circ \Rightarrow a = 18^\circ$$

$$\therefore y = 3 \times 18^\circ = 54^\circ \text{ and } z = 18^\circ \times 7 = 126^\circ$$

$$\text{Also, } x + y = 180^\circ$$

$$\Rightarrow x + 54^\circ = 180^\circ$$

$$\therefore x = 180^\circ - 54^\circ = 126^\circ$$

Hence, $x = 126^\circ$ **Ans.**

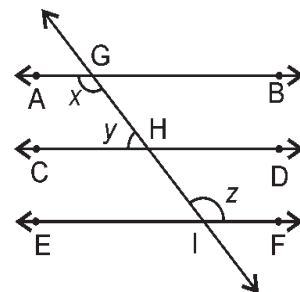
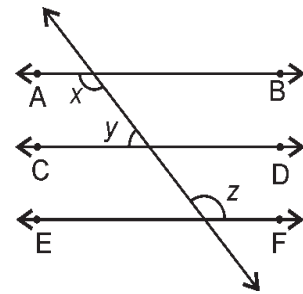

Q.3. In the figure, if $AB \parallel CD$, $EF \perp CD$ and $\angle GED = 126^\circ$. Find $\angle AGE$, $\angle GEF$ and $\angle FGE$.

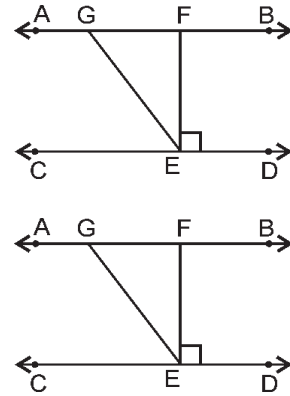

Sol. In the given figure, $AB \parallel CD$, $EF \perp CD$ and $\angle GED = 126^\circ$

$$\angle AGE = \angle LGE \text{ (Alternate angle)}$$

$$\therefore \angle AGE = 126^\circ$$

$$\text{Now, } \angle GEF = \angle GED - \angle DEF = 126^\circ - 90^\circ = 36^\circ \text{ (}\because \angle DEF = 90^\circ\text{)}$$

$$\text{Also, } \angle AGE + \angle FGE = 180^\circ \text{ (Linear pair axiom)}$$

$$\Rightarrow 126^\circ + \angle FGE = 180^\circ$$

$$\Rightarrow \angle FGE = 180^\circ - 126^\circ = 54^\circ$$

Q.4. In the figure, if $PQ \parallel ST$, $\angle PQR = 110^\circ$ and $\angle RST = 130^\circ$, find $\angle QRS$.

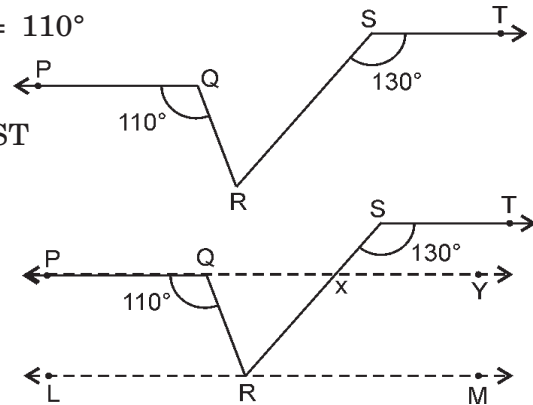

Sol. Extend PQ to Y and draw $LM \parallel ST$ through R.

$$\angle TSX = \angle QXS \text{ [Alternate angles]}$$

$$\Rightarrow \angle QXS = 130^\circ$$

$$\angle QXS + \angle RXQ = 180^\circ$$

$$\text{[Linear pair axiom]}$$

$$\Rightarrow \angle RXQ = 180^\circ - 130^\circ = 50^\circ \dots(1)$$

$$\angle PQR = \angle QRM \text{ [Alternate angles]}$$

$$\Rightarrow \angle QRM = 110^\circ \dots(2)$$

$$\angle RXQ = \angle XRM \text{ [Alternate angles]}$$

$$\Rightarrow \angle XRM = 50^\circ \text{ [By (1)]}$$

$$\begin{aligned} \angle QRS &= \angle QRM - \angle XRM \\ &= 110^\circ - 50^\circ = 60^\circ \text{ Ans.} \end{aligned}$$

Q.5. In the figure, if $AB \parallel CD$, $\angle APQ = 50^\circ$ and $\angle PRD = 127^\circ$, find x and y .

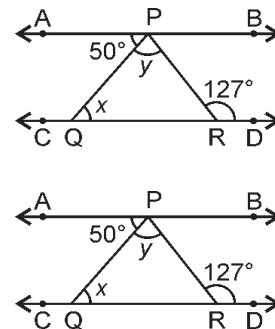

Sol. In the given figure, $AB \parallel CD$, $\angle APQ = 50^\circ$ and $\angle PRD = 127^\circ$

$$\begin{aligned} \angle APQ + \angle PQC &= 180^\circ \\ &\text{[Pair of consecutive interior angles are supplementary]} \end{aligned}$$

$$\Rightarrow 50^\circ + \angle PQC = 180^\circ$$

$$\Rightarrow \angle PQC = 180^\circ - 50^\circ = 130^\circ$$

$$\text{Now, } \angle PQC + \angle PQR = 180^\circ \text{ [Linear pair axiom]}$$

$$\Rightarrow 130^\circ + x = 180^\circ$$

$$\Rightarrow x = 180^\circ - 130^\circ = 50^\circ$$

$$\text{Also, } x + y = 127^\circ \text{ [Exterior angle of a triangle is equal to the sum of the two interior opposite angles]}$$

$$\Rightarrow 50^\circ + y = 127^\circ$$

$$\Rightarrow y = 127^\circ - 50^\circ = 77^\circ$$

$$\text{Hence, } x = 50^\circ \text{ and } y = 77^\circ \text{ Ans.}$$

Q.6. In the figure, PQ and RS are two mirrors placed parallel to each other. An incident ray AB strikes the mirror PQ at B , the reflected ray moves along the path BC and strikes the mirror RS at C and again reflects back along CD . Prove that $AB \parallel CD$.

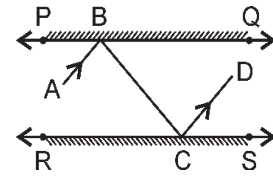

Sol. At point B , draw $BE \perp PQ$ and at point C , draw $CF \perp RS$.

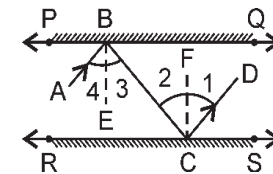

$\angle 1 = \angle 2$... (i)
 (Angle of incidence is equal to angle of reflection)

$\angle 3 = \angle 4$... (ii) [Same reason]

Also, $\angle 2 = \angle 3$... (iii) [Alternate angles]

$\Rightarrow \angle 1 = \angle 4$ [From (i), (ii), and (iii)]

$\Rightarrow 2\angle 1 = 2\angle 4$

$\Rightarrow \angle 1 + \angle 1 = \angle 4 + \angle 4$

$\Rightarrow \angle 1 + \angle 2 = \angle 3 + \angle 4$ [From (i) and (ii)]

$\Rightarrow \angle BCD = \angle ABC$

Hence, $AB \parallel CD$. [Alternate angles are equal] **Proved.**

6

LINES AND ANGLES

EXERCISE 6.3

Q.1. In the figure, sides QP and RQ of $\triangle PQR$ are produced to points S and T respectively. If $\angle SPR = 135^\circ$ and $\angle PQT = 110^\circ$, find $\angle PRQ$.

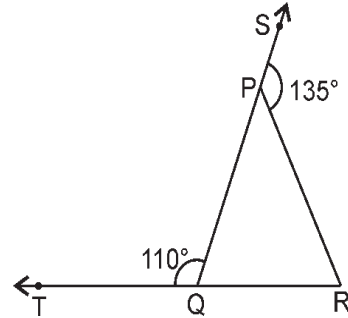

Sol. In the given figure, $\angle SPR = 135^\circ$ and $\angle PQT = 110^\circ$.

$$\angle PQT + \angle PQR = 180^\circ \quad \text{[Linear pair axiom]}$$

$$\Rightarrow 110^\circ + \angle PQR = 180^\circ$$

$$\Rightarrow \angle PQR = 180^\circ - 110^\circ = 70^\circ$$

$$\text{Also, } \angle SPR + \angle QPR = 180^\circ \quad \text{[Linear pair axiom]}$$

$$\Rightarrow 135^\circ + \angle QPR = 180^\circ$$

$$\Rightarrow \angle QPS = 180^\circ - 135^\circ = 45^\circ$$

Now, in the triangle PQR
 $\angle PQR + \angle PRQ + \angle QPR = 180^\circ$
 [Angle sum property of a triangle]

$$\Rightarrow 70^\circ + \angle PRQ + 45^\circ = 180^\circ$$

$$\Rightarrow \angle PRQ + 115^\circ = 180^\circ$$

$$\Rightarrow \angle PRQ = 180^\circ - 115^\circ = 65^\circ$$

Hence, $\angle PRQ = 65^\circ$ Ans.

Q.2. In the figure, $\angle X = 62^\circ$, $\angle XYZ = 54^\circ$. If YO and ZO are the bisectors of $\angle XYZ$ and $\angle XZY$ respectively of $\triangle XYZ$, find $\angle OZY$ and $\angle YOZ$.

Sol. In the given figure,
 $\angle X = 62^\circ$ and $\angle XYZ = 54^\circ$.

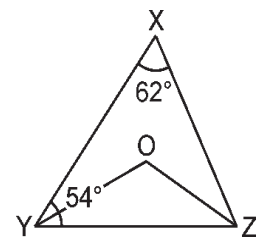
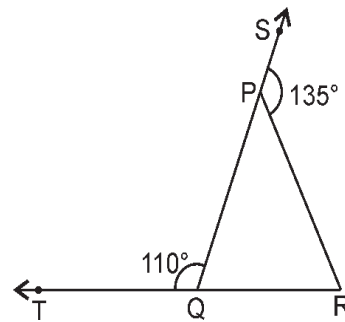

$$\angle XYZ + \angle XZY + \angle YXZ = 180^\circ \quad \dots(i)$$

[Angle sum property of a triangle]

$$\Rightarrow 54^\circ + \angle XZY + 62^\circ = 180^\circ$$

$$\Rightarrow \angle XZY + 116^\circ = 180^\circ$$

$$\Rightarrow \angle XZY = 180^\circ - 116^\circ = 64^\circ$$

Now, $\angle OZY = \frac{1}{2} \times \angle XZY$ [\because ZO is bisector of $\angle XZY$]

$$= \frac{1}{2} \times 64^\circ = 32^\circ$$

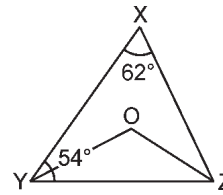

Similarly, $\angle OYZ = \frac{1}{2} \times 54^\circ = 27^\circ$

Now, in $\triangle OYZ$, we have

$$\angle OYZ + \angle OZY + \angle YOZ = 180^\circ \text{ [Angle sum property of a triangle]}$$

$$\Rightarrow 27^\circ + 32^\circ + \angle YOZ = 180^\circ$$

$$\Rightarrow \angle YOZ = 180^\circ - 59^\circ = 121^\circ$$

Hence, $\angle OZY = 32^\circ$ and $\angle YOZ = 121^\circ$ Ans.

Q.3. In the figure, if $AB \parallel DE$, $\angle BAC = 35^\circ$ and $\angle CDE = 53^\circ$, find $\angle DCE$.

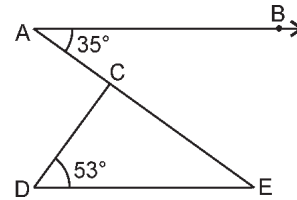

Sol. In the given figure

$$\angle BAC = \angle CED$$

[Alternate angles]

$$\Rightarrow \angle CED = 35^\circ$$

In $\triangle CDE$,

$$\angle CDE + \angle DCE + \angle CED = 180^\circ \text{ [Angle sum property of a triangle]}$$

$$\Rightarrow 53^\circ + \angle DCE + 35^\circ = 180^\circ$$

$$\Rightarrow \angle DCE + 88^\circ = 180^\circ$$

$$\Rightarrow \angle DCE = 180^\circ - 88^\circ = 92^\circ$$

Hence, $\angle DCE = 92^\circ$ Ans.

Q.4. In the figure, if lines PQ and RS intersect at point T, such that $\angle PRT = 40^\circ$, $\angle RPT = 95^\circ$ and $\angle TSQ = 75^\circ$, find $\angle SQT$.

Sol. In the given figure, lines PQ and RS intersect at point T, such that $\angle PRT = 40^\circ$, $\angle RPT = 95^\circ$ and $\angle TSQ = 75^\circ$.

In $\triangle PRT$

$$\angle PRT + \angle RPT + \angle PTR = 180^\circ$$

[Angle sum property of a triangle]

$$\Rightarrow 40^\circ + 95^\circ + \angle PTR = 180^\circ$$

$$\Rightarrow 135^\circ + \angle PTR = 180^\circ$$

$$\Rightarrow \angle PTR = 180^\circ - 135^\circ = 45^\circ$$

Also, $\angle PTR = \angle STQ$

$$\therefore \angle STQ = 45^\circ$$

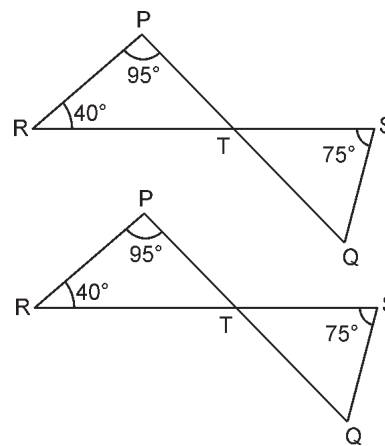

[Vertical opposite angles]

Now, in ΔSTQ ,
 $\angle STQ + \angle TSQ + \angle SQT = 180^\circ$ [Angle sum property of a triangle]
 $\Rightarrow 45^\circ + 75^\circ + \angle SQT = 180^\circ$
 $\Rightarrow 120^\circ + \angle SQT = 180^\circ$
 $\Rightarrow \angle SQT = 180^\circ - 120^\circ = 60^\circ$
Hence, $\angle SQT = 60^\circ$ **Ans.**

Q.5. In the figure, if $PT \perp PS$, $PQ \parallel SR$, $\angle SQR = 28^\circ$ and $\angle QRT = 65^\circ$, then find the values of x and y .

Sol. In the given figure, lines $PQ \perp PS$, $PQ \parallel SR$, $\angle SQR = 28^\circ$ and $\angle QRT = 65^\circ$

$\angle PQR = \angle QRT$ [Alternate angles]
 $\Rightarrow x + 28^\circ = 65^\circ$
 $\Rightarrow x = 65^\circ - 28^\circ = 37^\circ$

In ΔPQS ,
 $\angle SPQ + \angle PQS + \angle QSP = 180^\circ$ [Angle sum property of a triangle]
 $\Rightarrow 90^\circ + 37^\circ + y = 180^\circ$
 $\Rightarrow 127^\circ + y = 180^\circ$
 $\Rightarrow y = 180^\circ - 127^\circ = 53^\circ$

Hence, $x = 37^\circ$ and $y = 53^\circ$ **Ans.**

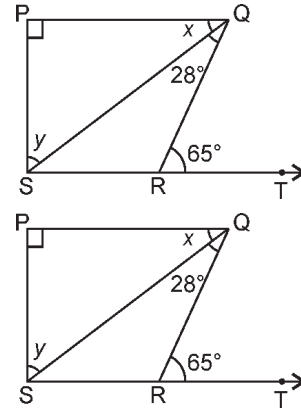

Q.6. In the figure, the side QR of ΔPQR is produced to a point S . If the bisectors of $\angle PQR$ and $\angle PRS$ meet at point T , then prove that $\angle QTR = \frac{1}{2} \angle QPR$.

Sol. Exterior $\angle PRS = \angle PQR + \angle QPR$
[Exterior angle property]

Therefore, $\frac{1}{2} \angle PRS = \frac{1}{2} \angle PQR + \frac{1}{2} \angle QPR$

$\Rightarrow \angle TRS = \angle TQR + \frac{1}{2} \angle QPR$

But in ΔQTR ,

Exterior $\angle TRS = \angle TQR + \angle QTR$... (ii)
[Exterior angles property]

Therefore, from (i) and (ii)

$\angle TQR + \angle QTR = \angle TQR + \frac{1}{2} \angle QPR$

$\Rightarrow \angle QTR = \frac{1}{2} \angle QPR$ **Proved.**

